

Input Connector Pin Identification

The port connector wiring is as follows.

Pin number	Connection
1	h (8)
2	g (7)
3	f (6)
4	e (5)
5	Ground
6	+5VDC
7	d (4)
8	c (3)
9	b (2)
10	a (1)

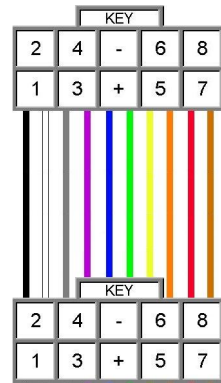

10 position IDC connector

Output Options

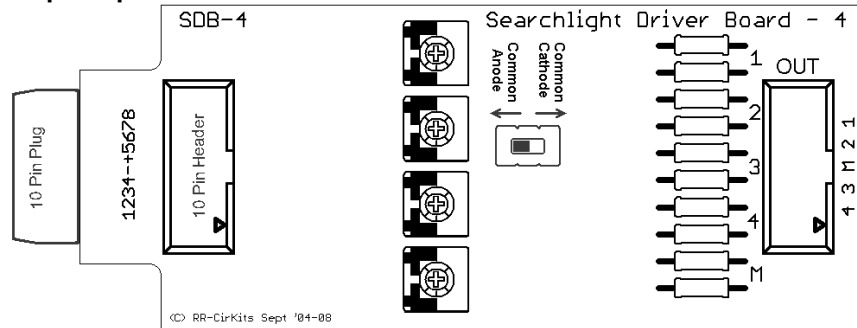

Current Limiting Resistors.

To increase LED brightness add resistors as indicated above. Each resistor controls the brightness of one LED of a three lead connection. Do not use less than 100 ohm resistors. For bi-polar LEDs each pair of resistors is in series with one LED. Do not use less than 47 ohm resistors with bi-polar LEDs.

Polarity Switch.

The switch controls the board's output polarity. Either common Anode or common Cathode 3 lead LED connections may be used. With bi-polar LEDs changing the polarity switch reverses the red and green indications.

RR-CirKits Contact Information

RR-CirKits, Inc.
7918 Royal Ct.
Waxhaw, NC USA 28173

<http://www.rr-cirkits.com>
sales@rr-cirkits.com
service@rr-cirkits.com
1-704-843-3769
Fax: 1-704-243-4310

(Manual Rev-a ©14-April-'09)

RR-CirKits

Specializing in Affordable Electronics for Model Railroads

SDB-4

3 Aspect Searchlight Signal Driver - 4 Heads

User's Guide

Modular I/O Cards

All RR-CirKits Tower Controller Modular I/O cards are designed to either be plugged directly into the TC-64, or else mounted in Tyco 3-1/4" Snap-Track® mounted to the bench work and connected with short ribbon cables. (Snap-Track® is a plastic channel designed to mount PC cards to a chassis, not something to run trains on.) Each Modular I/O card is equipped with two connectors to facilitate these connection options.

SDB-4 (Searchlight Signal Driver - 4 head)

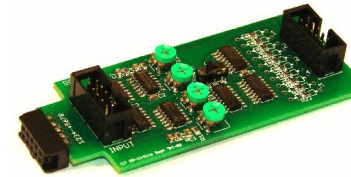

One of the best descriptions of CTC signalling from both a modeller's and prototype perspective that I am aware of may be found at the [Control Train Components](http://www.ctcparts.com/aboutprint.htm) web site.

(<http://www.ctcparts.com/aboutprint.htm>)

Power Connections

This Modular I/O board gets its power directly from the Tower Controller. It includes on-board oscillators for each signal to adjust the color balance between the Red and Green LED chips to get an acceptable Yellow.

Do NOT use this board to drive anything other than dual color LEDs, and do NOT connect either the LEDs nor other board outputs to anything other than each other. Bi-polar LEDs do not have a common connection, and may not be tied to a signal mast nor to each other.

Signal Head Wiring

Single connectors are shown in these schematic drawings, but normally each signal mast will have its own connector spaced out in daisy chain configuration along a single ribbon cable coming from the driver card.

All the following circuits may be built as either common anode or common cathode versions. Simply switch the polarity selector on the driver board to match. Common anode versions are shown. To wire

common cathode versions just reverse the direction of each LED.

SearchLight Signals using directly connected 3 lead tri-color LEDs driven with a SDB-4 board.

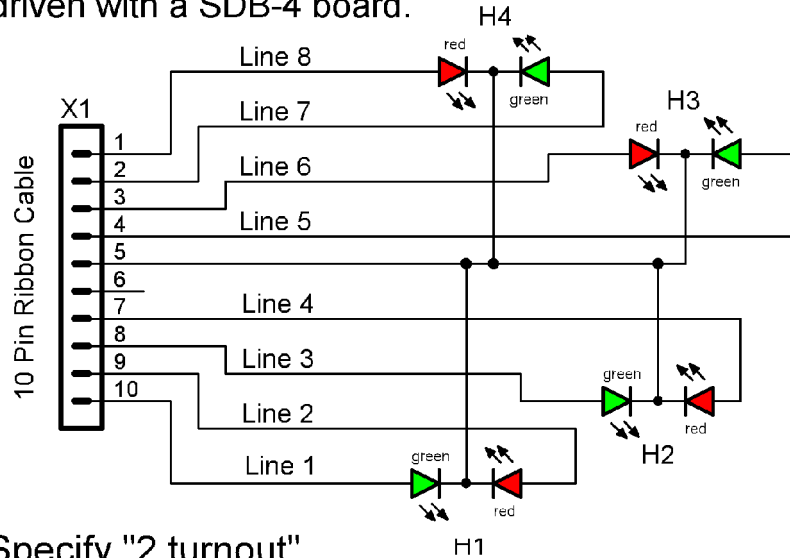

Specify "2 turnout" or "SE8c" mode

Searchlight Signals using three lead LEDs.

Searchlight signals are more difficult to drive than color light signals due to the necessity of matching the red and green drives very closely to assure a balanced yellow. To allow this color matching the SDB-4 includes pots to adjust the balance between the green LED 'on' time and the red LED 'on' time. The on board limiting resistor values may also be changed between the red and green diodes to improve the brightness of the signals. We suggest 330 ohms for the green and 1K ohms for the red circuits. Then adjust the oscillators to fine tune the color balance. The resistor at the appropriate 'M' position should be jumpered to provide a common reference to the LEDs.

Marker Light LED connections.

Fixed marker lights may be connected between lines 5 and 6. Adjust their brightness by placing a resistor in the appropriate 'M' location and a jumper at the other 'M' location.

Searchlight Signals using bi-polar LEDs driven with a SDB-4 board.

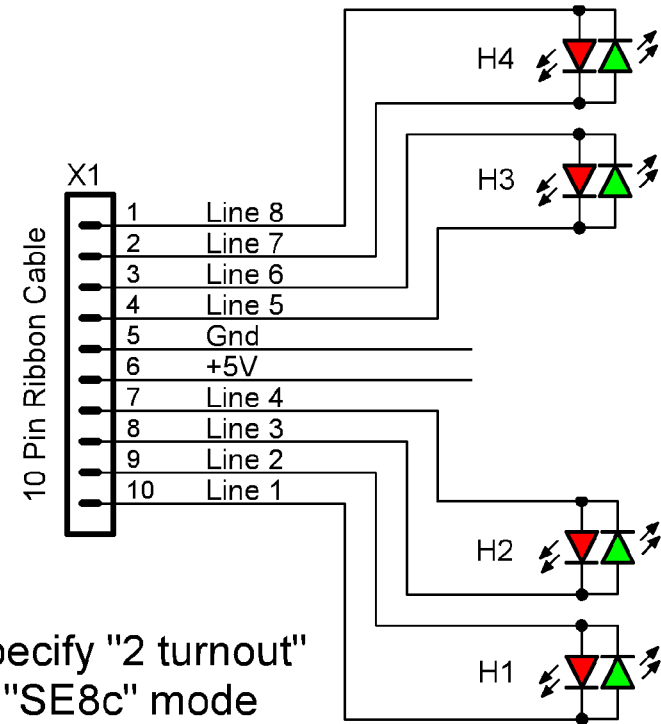

Specify "2 turnout" or "SE8c" mode

Searchlight Signals using Bi-polar LEDs.

Driving Bi-polar LEDs to indicate yellow requires a circuit that can switch between the green and red polarities fast enough to be invisible to the human eye. From a distance the eye then merges to two colors to appear as yellow. The brightness of a signal may be improved by changing the series resistance values. Both color LEDs are in series with both resistors for each head. You may change either or both to change the signal brightness. Do not use less than 47 ohms per each resistor.

Connections and Options

There are two input connections and one output connection on the SDB-4 board. The two input connections use the standard TC-64 10 pin cable connection that is shared by all Tower Controller Modular I/O cards. Both a male and female connector is provided, and either may be used depending on your requirements. The RR-CirKits FOB-A (Fan Out Board - Direct connection) may simplify your connections at the signals.